

FnIO M – Series :

M7001

M7001 (Redundancy Power)

Table of Contents

Table of Contents.....	2
History.....	3
1.ENVIRONMENT SPECIFICATION.....	4
2.M7001 (Redundancy Power Module).....	5
2.1.M7001 Specification.....	5
2.2.M7001 Wiring Diagram.....	6
2.3.M7001 LED Indicator.....	7
2.3.1.LED Indicator.....	7
2.3.2. RUN(RUN Status LED).....	7
2.3.3. PRI(Primary Status LED).....	7
2.3.4.ACT(Active Status LED).....	7
2.3.5.Field Power LED (Field Power Status LED).....	7
2.4.Power Expansion Function.....	8
2.4.1.Power Expansion Configuration Image.....	8
2.4.2.Standard Power Configuration in IOGuidePro.....	8
2.4.3.Max Power Exceeded	9
2.4.4.Expansion Power Location	9
2.5.Power Redundancy Function.....	10
2.5.1.Power Redundancy Configuration Image.....	10
2.5.2.Redundancy Power Configuration in IOGuidePro.....	10
2.6.Dummy Module Location.....	11
2.7.M7001 Mapping data in to image table.....	12

History

REV.	PAGES	REMARKS	DATE	Editor
-		Preliminary	2018/06/18	BS HA
1.00			2020/02/11	CW SEO
1.01		Image, UL Spec, Torque, Hotswap Function	2020/04/21	CW SEO
1.02		Vibration specification, Product certification changed	2020/04/27	CW SEO
1.03	14~18	Added ATEX certificate	2020/05/07	BS HA
1.04		Remove Description pages of Hot Swap Function, Use in Hazardous Environments and Caution(Before using the unit)	2020/12/09	SJ LIM
1.05	5	Power dissipation changed	2021/04/13	BS HA

1. ENVIRONMENT SPECIFICATION

Environmental specification	
Operating Temperature	-25°C~60°C
UL Temperature	-2°C~55°C
Storage Temperature	-40°C~85°C
Relative Humidity	5% ~ 90% non-condensing
Mounting	DIN rail
General specification	
Shock Operating	IEC 60068-2-27
Vibration Resistance	Based on IEC 60068-2-6 DNVGL-CG-0039 : Vibration Class B, 4g
Industrial Emissions	EN 61000-6-4/A11 : 2011
Industrial Immunity	EN 61000-6-2 : 2005
Installation Position	Vertical and horizontal installation is available.
Product Certifications	CE, UL, FCC, KR, ABS, ATEX, DNV

2. M7001 (Redundancy Power Module)

2.1. M7001 Specification

Items	Specification
Input Specification	
System Input Voltage Range	15Vdc to 28.8Vdc
UL System Power	Supply voltage : 24Vdc nominal, Class 2
System Power Input Voltage	Supply voltage : 24Vdc nominal Supply voltage range : 15~28.8Vdc Protection : Output current limit Reverse polarity protection
Indicators	4 LEDs 1 Green, M-Bus Status (RUN) 1 Green, Primary Status(PRI) 1 Green, Active Status (ACT) 1 Green, Field Power Enable (Field Power)
UL Field Power	Supply voltage : 24Vdc nominal, Class 2
Field Power Input Voltage	Supply voltage : 24Vdc typical(±20%) * Field Power Range is different depending on IO Module series. Refer to IO Module's Specification.
M-bus Output Voltage	Max 5Vdc, 2A
General specification	
Power Dissipation	Max. 30mA @ 24Vdc
Single Power Current for I/O Module	2.0A @ 5Vdc
Isolation	System power to internal logic : Non-isolation System power I/O driver : Isolation
Max. Current Field Power Contact	DC 10A Max
Single Wire	0.205mm ^φ - 1.3mm ^φ (24-16 AWG)
Torque	0.8Nm(7 lb-in)
Weight	72g
Module Size	12mm x 110mm x 75mm
Hot Swap	Possible
Environment Condition	Refer to '1. Environment Specification'

* Class 2, adjacent to voltage rating (30Vmax)

2.2. M7001 Wiring Diagram

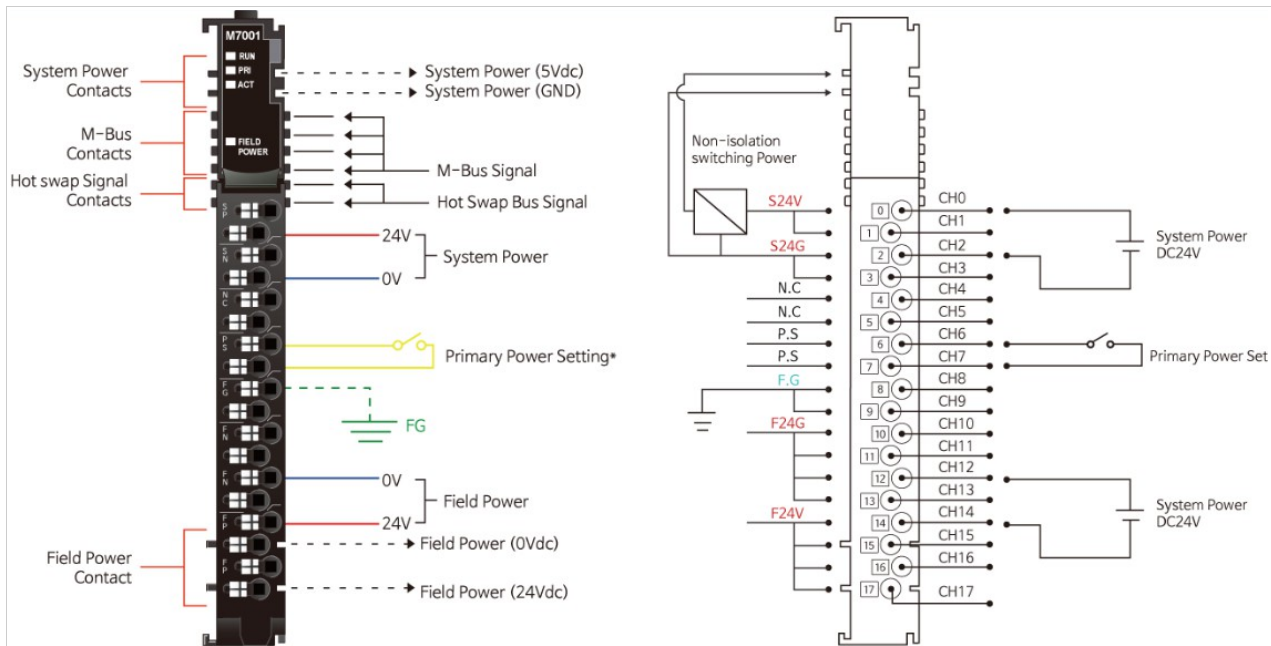

* Primary Power Setting (P.S pin)

- Short the P.S pin to set one of the two M7001 as the primary power.

Pin No.	Signal Description
0	SP System Power, 24V
1	SP System Power, 24V
2	SN System Power, 0V(GND)
3	SN System Power, 0V(GND)
4	NC -----
5	NC -----
6	PS Primary Power Setting
7	PS Primary Power Setting
8	FG F.G
9	FG F.G
10	FN Field Power 0V (GND)
11	FN Field Power 0V (GND)
12	FN Field Power 0V (GND)
13	FN Field Power 0V (GND)
14	FP Field Power 24V
15	FP Field Power 24V
16	FP Field Power 24V
17	FP Field Power 24V

Series No	Through Air	Over Surface	CTI
RTB18C	1.5mm	1.5mm	175≤CTI≤400

Spacings : The following minimum spacing in inches (millimeters) shall be maintained between uninsulated live parts of opposite polarity; and between an uninsulated live part and a grounded Part including any mounting surface or exposed metal part.

2.3. M7001 LED Indicator

2.3.1. LED Indicator



LED No.	LED Function / Description	LED Color
RUN	M-Bus Status	Green
PRI	Primary Status	Green
ACT	Active	Green
Field Power	Field Power Enable	Green

2.3.2. RUN(RUN Status LED)

Status	LED	To indicate
Supplied System power	Green	Supplied 5Vdc system power.
No System power	OFF	Not Supplied 5Vdc system power.

2.3.3. PRI(Primary Status LED)

Status	LED	To indicate
Primary Setting	Green	Primary power module.
Not Primary Setting	OFF	Secondary power module or not use redundancy function.

2.3.4. ACT(Active Status LED)

Status	LED	To indicate
Main Power Module	Green	When the Power Module is operating in main operation.
Substitution Power Module	OFF	Standby with Substitution Power Module.

2.3.5. Field Power LED (Field Power Status LED)

Status	LED	To indicate
No field power	OFF	Not supplied 24Vdc field power.
Supplied field power	Green	Supplied 24Vdc field power.

2.4. Power Redundancy Function

2.4.1. Power Redundancy Configuration Image

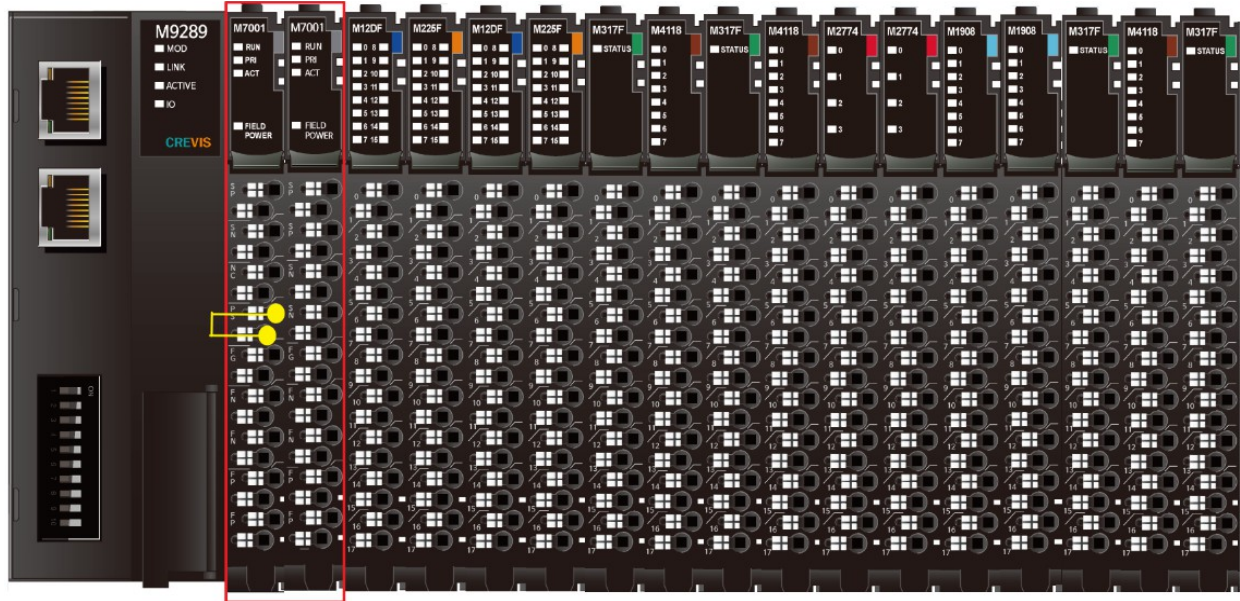

If you want power redundancy function, you must set primary power pin(P.S pin). Among the two power modules, the power that sets the P.S pin is the primary, and the other is the secondary.

2.5. M7001 Mapping data in to image table

Bit No	Bit7	Bit6	Bit5	Bit4	Bit3	Bit2	Bit1	Bit0
Byte1	-	-	-	-	FIELD	ACT	PRI	RUN

- Input Module Data

D7	D6	D5	D4	D3	D2	D1	D0
----	----	----	----	----	----	----	----



- Input Module Value

Bit No	Bit7	Bit6	Bit5	Bit4	Bit3	Bit2	Bit1	Bit0
Byte0	D7	D6	D5	D4	D3	D2	D1	D0